

深圳晨歌电脑服务公司

SD 卡产品技术参数规格书

Approval sheet

SD Memory Card

SD memory card feature

Design	KONLIN Standard	
Contents	None (OEM Design Available)	ID, MKB Programmed (KONLIN Specific)
SD Specification	SD Memory Card Specifications Ver.1.10 Compliant	
Security Functions	SD Security Specification Ver.1.10 Compliant (CPRM Based) *CPRM: Contents Protection for Recording Media Specification	
Logical Format	SD Files System Specification Ver.1.0 Compliant	

請插入圖片

Mechanical Write Protect Switch

A mechanical sliding tablet on the side of the card can use for write protect switch. The host system shall be responsible for this function.

The card is in a "Write Protected" status when the tablet is located on the "Lock position. The host system will not write nor format the card in this status.

The card is in a "Write Enabled" status when the tablet is moved to the opposite position (Un-Lock). (Please refer the figures below for the tablet polarity.)

Write Protected

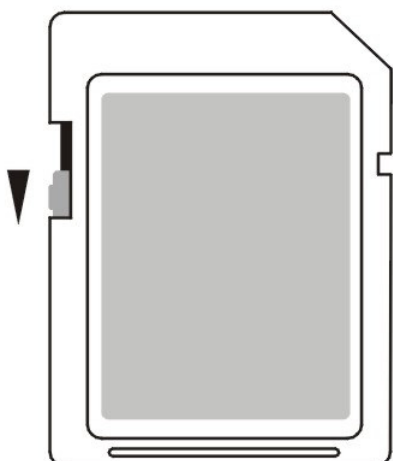

Write Enabled

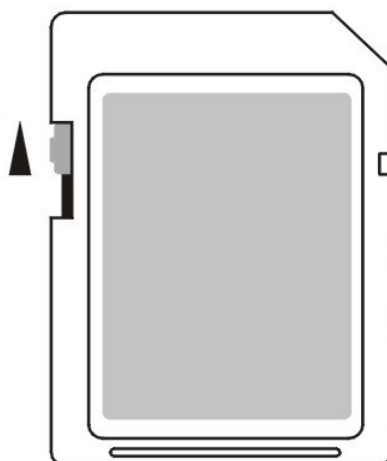

SD memory pin assignment

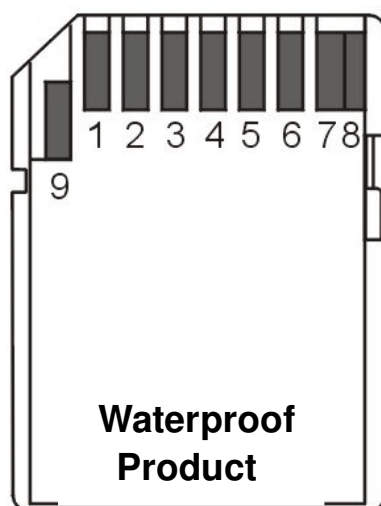

SD memory card pins definition

SD Mode			
PIN NO	NAME	TYPE	DESCRIPTION
1	CD/DAT3	I/O/PP	Card detect/ Data line [Bit 3]
2	CMD	PP	Command / Response
3	VSS1	S	Supply voltage ground
4	VDD	S	Supply voltage
5	CLK	I	Clock
6	VSS2	S	Supply voltage ground
7	DAT0	I/O/PP	Data line [Bit 0]
8	DAT1	I/O/PP	Data line [Bit 1]

9	DAT2	I/O/PP	Data line [Bit 2]
---	------	--------	-------------------

SPI Mode			
PIN NO	NAME	TYPE	DESCRIPTION
1	CS	I	Chip select (Negative true)
2	DI	I	DATA IN
3	VSS1	S	Supply voltage ground
4	VDD	S	Supply voltage
5	SCLK	I	Clock
6	VSS2	S	Supply voltage ground
7	DO	O/PP	DATA OUT
8	--	--	Reserved (*)
9	--	--	Reserved (*)

Note: 1) S: power supply; I: input; O: output; PP: push-pull drivers

- 2) The DAT line for read - only cards is output only (The card stack initialization uses only the CMD channel and is therefore compatible for all cards.
- 3) *: Host side should pull up these signals with 10-100k ohm resistance in the SPI Mode
- 4) **: the pins should be left open

Maximum Durable Condition

Temperature	Operating	-25°C ~ 85°C
	Storage	-40 °C~ 85°C
Humidity	Operating	25 °C /95 % relative humidity
	Storage	40 °C /93 % relative humidity / 500h
ESD	Air Discharge	Above ± 15KV
	Coupling Plane Discharge	Above ± 8KV
Vibration	Operating	15G peak-to-peak max.
	Storage	15G peak-to-peak max.
Shock		1000G max.
Program/Erase cycles		100K Cycles

Note: 1) "This table shows the maximum range which can operate in some condition. However, KONLIN DOES NOT mean that products should operate this condition for a long time.

- 2) KONLIN special injection process makes KONLIN product no any gap, so it is waterproof and dustproof. If you are careless to leave card in wash machine, you still can use it as normal.

Function Architecture

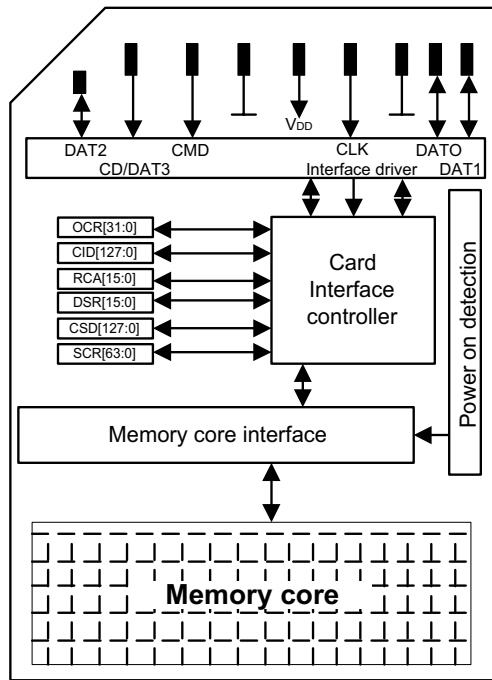

Power Supply Voltage

(Operation Condition)

Parameter	Symbol	Min.	Max.	Unit	Remark
Supply voltage 1	V_{DD}	2.0	3.6	V	Please see:1)
Supply voltage 2	V_{DD}	2.7	3.6	V	Please see:2)
Supply voltage differentials	V_{SS1}, V_{SS2}	-0.3	0.3	V	
Power up time			250	ms	From 0v to VDD min

- Note: 1) "Supply voltage 1" means SD card under card initial status. This status allows that V_{DD} & command: CMD0, 15, 55, ACMD41 have a wide operating voltage range
- 2) "Supply voltage 2" means SD card under normal operating status. The normal operating voltage range is written in OCR register.

DC Characteristics

Parameter	Symbol	Min.	Typical	Max.	Unit	Remark
Peak voltage on all lines		-0.3		$V_{DD} + 0.3$	V	
Input Leakage Current	I_{LI}			10	μA	
Output Leakage Current	I_{LO}			10	μA	
Un-initial current				1	mA	
Stand by current <initial>				300	μA	
Operating Current	I_{CC1}		20	35	mA	
Output HIGH voltage	V_{OH}	$0.75 * V_{DD}$			V	$I_{OH} = -100 \mu A @ V_{DD} \text{ min}$
Output LOW voltage	V_{OL}			$0.125 * V_{DD}$	V	$I_{OL} = 100 \mu A @ V_{DD} \text{ min}$
Input HIGH voltage	V_{IH}	$0.625 * V_{DD}$		$V_{DD} + 0.3$	V	
Input LOW voltage	V_{IL}	$V_{SS} - 0.3$		$0.25 * V_{DD}$	V	

Bus signal load line

The total capacitance C_L the CLK line of the miniSD Memory Card bus is the sum of the bus master capacitance C_{HOST} , the bus capacitance C_{BUS} itself and the capacitance C_{CARD} of each card connected to this line:

$$C_L = C_{HOST} + C_{BUS} + N * C_{CARD}$$

where N is the number of connected cards. Requiring the sum of the host and bus capacitances not to exceed 30 pF for up to 10 cards, and 40 pF for up to 30 cards, the following values must not be exceeded:

Parameter	Symbol	Min.	Max.	Unit	Remark
Pull-up resistance	R_{CMD}/R_{DAT}	10	100	K Ω	to prevent bus floating
Bus signal line capacitance	C_L		250	pF	$f_{PP} < 5$ MHz, 21 cards
Bus signal line capacitance	C_L		100	pF	$f_{PP} < 20$ MHz, 7 cards
Single card capacitance	C_{CARD}		10	pF	
Maximum signal line inductance			16	nH	$f_{PP} < 20$ MHz
Pull-up resistance inside card (pin1)	R_{DAT3}	10	90	K Ω	May be used for card Detection

Note: That the total capacitance of CMD and DAT lines will be consist of C_{HOST} , C_{BUS} and one C_{CARD} only since they are connected separately to the SD Memory Card host.

SD Memory Card Hardware interface

SD Card interface

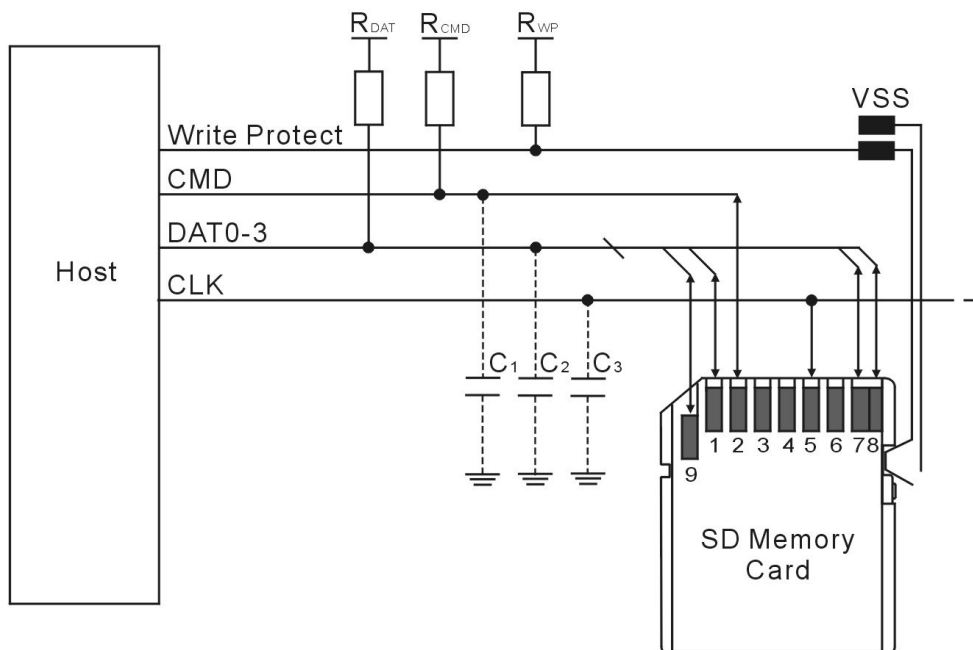

Timing waveform

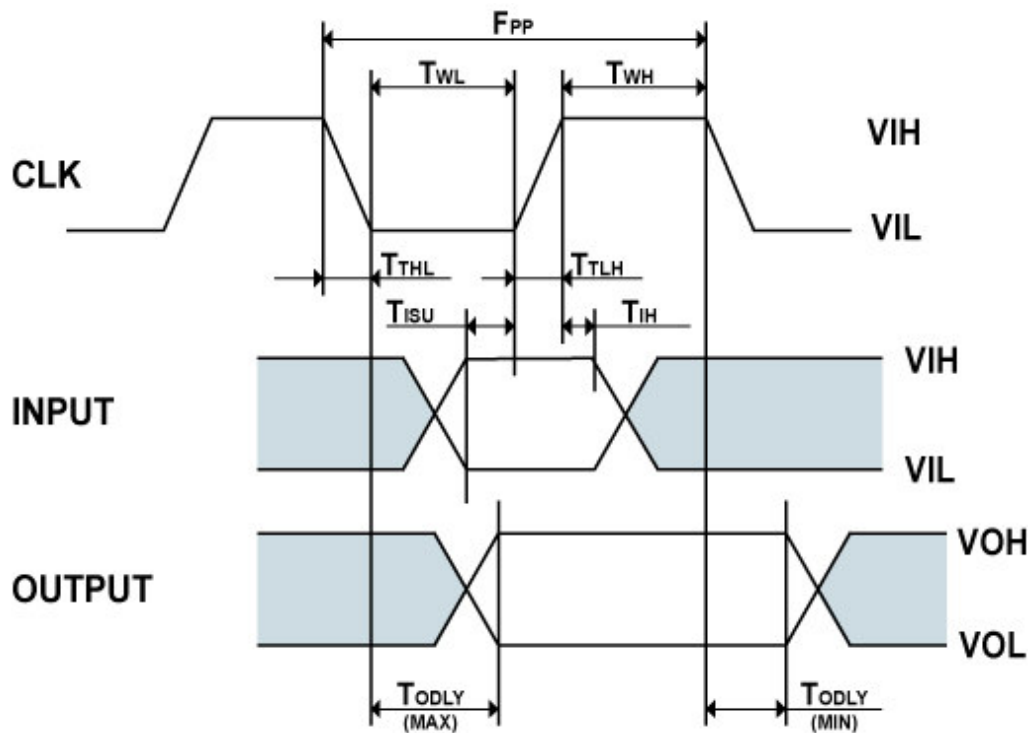

AC characteristics

Parameter	Symbol	Min.	Max.	Unit	Remark
Clock CLK (All values are referred to min (VIH) and max (VIL))					
Clock frequency in any state	F_{STY}	0	25	MHz	CL < 100 pF, (7 cards)
Clock frequency	F_{PP}	0.1	25	MHz	CL < 100 pF, (7 cards)
Data Transfer Mode					
Clock frequency	F_{OD}	100K	400K	KHz	CL < 250 pF, (21 cards)
Card Identification Mode					
Clock low time	T_{WL}	10		ns	CL < 100 pF, (7 cards)
Clock high time	T_{WH}	10		ns	CL < 100 pF, (7 cards)
Clock rise time	T_{TLH}		10	ns	CL < 100 pF, (7 cards)
Clock fall time	T_{THL}		10	ns	CL < 100 pF, (7 cards)
Clock low time	T_{WL}	50		ns	CL < 250 pF, (21 cards)
Clock high time	T_{WH}	50		ns	CL < 250 pF, (21 cards)
Clock rise time	T_{TLH}		50	ns	CL < 250 pF, (21 cards)
Clock fall time	T_{THL}		50	ns	CL < 250 pF, (21 cards)
Inputs CMD, DAT (referenced to CLK)					
Input setup time	T_{ISU}	5		ns	CL < 25 pF (1 card)
Input hold time	T_{IH}	5		ns	CL < 25 pF (1 card)
Outputs CMD, DAT (referenced to CLK)					
Output Delay Time	T_{ODLY}	0	14	ns	CL < 25 pF (1 card)

Data Transfer Mode					
Output Delay Time	TODLY	0	50	ns	CL < 25 pF (1 card)
Card Identification Mode					

Note: 1) Rise and fall times are measured from 10%-90% of voltage level

Card register

The SD card has six registers and SD Status information: CID, OCR, CSD, RCA, DSR, SCR. The detail definition as follow table:

Resister	Bit Width	Description
Name		
CID	128	Card Identification information
OCR	32	Operation Conditions Registers
CSD	128	Card specific information
SCR	64	SD Memory Card's Special features
RCA	16	Relative Card Address
DSR	16	Driver Stage Register

CID Register

The Card Identification (CID) register is 128-bit width. It contains the card identification information used during the Card Identification phase.

OCR Register

This 32-bit register describes operating voltage range and status bit in the power supply.

CSD Register

The Card-Specific Data (CID) register provides information on how to access the cards contents. Some field of this register can be writable by PROGRAM_CSD(CMD27). This register is 128bit width

SCR Register

The SD Card Configuration (SCR) register provides information on SD Memory Card's special features. This register is 64bit width.

RCA Register

The writable 16bit relative card address register carries the card address in SD Card mode.

DSR Register

The Driver Stage Register (DSR) register provides an optional function for output driver condition. This register is 16bit width.

Product packing

ITEM	MATERIAL	QTY
Tray	Pet	60
Inner Pack	250 Pounds Kraft Paper with flute B Corrugated Paper	10
Carton	Five-Layered corrugated	1

Label

All dimensions in millimeters

Laser Mark



Note :

[Remark]

xx(Capacity)xxx1xxxxxxxx(Lot Number 1)

xx(Capacity)xxx2xxxxxxxx(Lot Number 2)

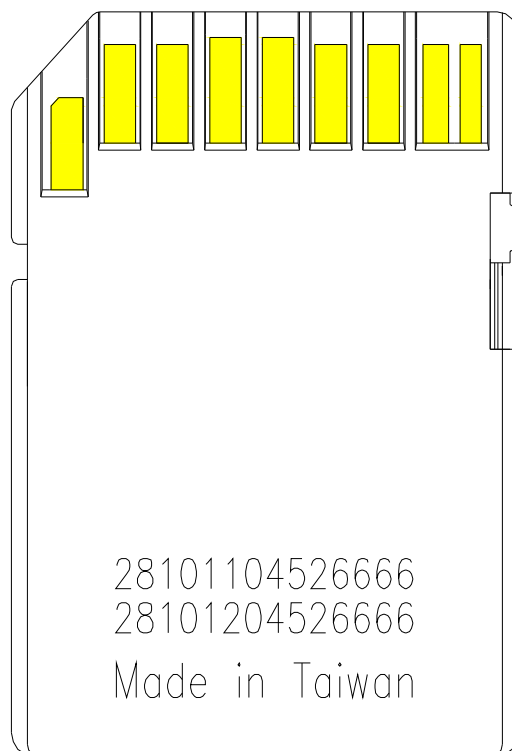

Mechanical descriptions

Length	32 mm ± 0.1 mm
Width	24 mm ± 0.1 mm
Thickness	2.1 mm ± 0.15 mm
Mass	< 3.0 g

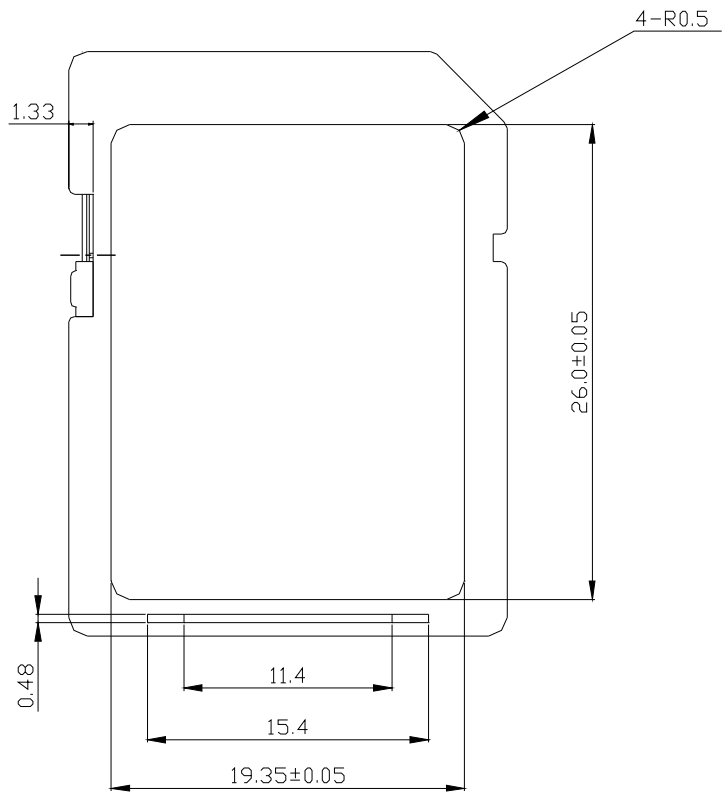

All dimensions in millimeters



T